

# Clarke® **METALWORKER**



## **ELECTRIC DRILL BIT SHARPENER**

MODEL NO: CBS20

PART NO: 6480231

## **OPERATION & MAINTENANCE INSTRUCTIONS**

UK  
PA | CE



ORIGINAL INSTRUCTIONS

DL0424 Rev 1

---

## INTRODUCTION

---

Thank you for purchasing this CLARKE Electric Drill Bit Sharpener.

Before attempting to use this product, please read this manual thoroughly and follow the instructions carefully. In doing so you will ensure the safety of yourself and that of others around you, and you can look forward to your purchase giving you long and satisfactory service.

---

## IMPORTANT

---

Please read all of the safety and operating instructions carefully before using this product. Please pay particular attention to all sections of these instructions that display warning symbols and notices.



**WARNING: THIS IS A WARNING SYMBOL. THIS SYMBOL IS USED THROUGHOUT THE USER GUIDE WHENEVER THERE IS A RISK OF PERSONAL INJURY. ENSURE THAT THESE WARNINGS ARE READ AND UNDERSTOOD AT ALL TIMES.**

---

## GUARANTEE

---

This product is guaranteed against faulty manufacture for a period of 12 months from the date of purchase. Please keep your receipt which will be required as proof of purchase.

This guarantee is invalid if the product is found to have been abused or tampered with in any way, or not used for the purpose for which it was intended.

Faulty goods should be returned to their place of purchase, no product can be returned to us without prior permission.

This guarantee does not effect your statutory rights.

# PRODUCT OVERVIEW







NO.	DESCRIPTION
1	Grinding Stone Height Adjustment Knob
2	Head Assembly
3	On/Off Switch

---

## SAFETY SYMBOLS

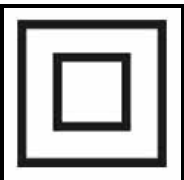
---

	Read instruction manual before use		Wear Eye Protection
	Class 2 Double Insulated		Indoor Use Only

---

## ENVIRONMENTAL RECYCLING POLICY

---



Through purchase of this product, the customer is taking on the obligation to deal with the WEEE in accordance with the WEEE regulations in relation to the treatment, recycling & recovery and environmentally sound disposal of the WEEE.

In effect, this means that this product must not be disposed of with general household waste. It must be disposed of according to the laws governing Waste Electrical and Electronic Equipment (WEEE) at a recognised disposal facility.

---

## GENERAL SAFETY RULES

---



**WARNING: WHEN USING ELECTRIC TOOLS, MACHINES, OR EQUIPMENT, BASIC SAFETY PRECAUTIONS SHOULD ALWAYS BE FOLLOWED TO REDUCE THE RISK OF FIRE, ELECTRIC SHOCK AND PERSONAL INJURY.**

1. **KEEP WORK AREA CLEAN.** Cluttered areas invite injuries. Keep work area well lit.
2. **NEVER** use power tools in damp, wet, or poorly lit locations. **DO NOT** expose to rain. **DO NOT** use electrically powered tools in the presence of flammable gases or liquids.
3. **KEEP CHILDREN AWAY.** Children must never be allowed in the work area. **DO NOT** let them handle machines, tools, or extension cable.

4. **STORE IDLE EQUIPMENT.** When not in use, tools should be locked up in a dry location to inhibit rust. Always lock up tools and keep out of reach of children.
5. **DO NOT FORCE THE TOOL.** It will do the job better and more safely at the rate for which it was intended.
6. **DRESS CORRECTLY. DO NOT** wear loose clothing or jewellery which could be caught in moving parts. Wear a hair net if you have long hair.
7. **USE EYE, EAR AND HAND PROTECTION.** Always wear approved impact safety goggles.
8. **DO NOT ABUSE THE POWER CABLE. DO NOT** yank it to disconnect it from the socket. **DO NOT** carry tools by the cable.
9. **DISCONNECT POWER.** Unplug when not in use, before servicing, and when changing accessories.
10. **AVOID UNINTENTIONAL STARTING.** Be sure the switch is in the **OFF** position when not in use and before plugging in.
11. **STAY ALERT.** Watch what you are doing, use common sense. **DO NOT** operate any tool when you are tired.
12. **DO NOT OPERATE TOOL IF UNDER THE INFLUENCE OF ALCOHOL OR DRUGS.** If there is any doubt, **DO NOT** operate the tool.
13. **CHECK DAMAGED PARTS.** Before using any tool, any part that appears damaged should be carefully checked to determine that it will operate properly and perform its intended function. **DO NOT** use the tool if the switch does not turn the tool on and off correctly.
14. **GUARD AGAINST ELECTRIC SHOCK.** Prevent body contact with grounded surfaces such as pipes, radiators.
15. **REPLACEMENT PARTS AND ACCESSORIES.** When servicing, use only identical replacement parts. Use of any other parts will void the warranty. Only use accessories intended for use with this tool.
16. **KEEP AWAY FROM LIQUIDS.** This tool is designed for dry sharpening operations only. **DO NOT** use any sharpening oils.
17. **HEAT PRODUCED WHEN SHARPENING.** The sharpening head and any bits being sharpened will become hot. Be careful when handling; allow drill tips to cool before storing.

---

## TOOL SPECIFIC SAFETY RULES

---

1. Make sure that flammable materials or materials that may explode are kept out of the immediate vicinity.
2. **DO NOT** overload the tool. Only use the device for its intended purpose.
3. Make sure you are positioned firmly and with a natural stance when working with the tool.
4. Make sure the grinding stone and head assembly are correctly seated and installed before switching on the tool.
5. Prevent overheating of the tool and the drill bit.
6. Guide the mains cable in such a way that it cannot be caught by the tool.
7. **NEVER** remove too much material in a single process. It is better to remove small amounts in multiple processes.
8. The tool should only be operated by a single operator at any one time.
9. **ALWAYS** wait until the grinding stone has come to a standstill before removing contamination, etc. from the working area/tool.
10. **NEVER** leave the tool to run unattended.
11. Only use grinding stones that are in perfect condition.
12. Remember that moving parts may be located behind ventilation and venting slots.
13. Ensure that the ventilation slots are always free of obstructions.
14. Check the grinding stone before each use. **DO NOT** use the device if the grinding stone is broken, has a crack or is damaged in any other way. Handle and store the grinding stone with care.
15. Make sure that the grinding stone is correctly fitted and secured. Allow the device to operate in idle for 30 seconds in a safe location. Immediately stop the device if there are faults.
16. Symbols affixed to your device **SHOULD NOT** be removed or covered. Information on the device that is no longer legible should be replaced immediately.

# ELECTRICAL CONNECTIONS



**WARNING! Read these electrical safety instructions thoroughly before connecting the product to the mains supply.**

Before switching the product on, make sure that the voltage of your electricity supply is the same as that indicated on the rating plate. This product is designed to operate on 230VAC 50Hz. Connecting it to any other power source may cause damage.

This product may be fitted with a non-rewireable plug. If it is necessary to change the fuse in the plug, the fuse cover must be refitted. If the fuse cover becomes lost or damaged, the plug must not be used until a suitable replacement is obtained.

If the plug has to be changed because it is not suitable for your socket, or due to damage, it should be cut off and a replacement fitted, following the wiring instructions shown below. The old plug must be disposed of safely, as insertion into a mains socket could cause an electrical hazard.

If the colours of the wires in the power cable of this product do not correspond with the markings on the terminals of your plug, proceed as follows.

- The **Blue** wire must be connected to the terminal marked **N** or coloured **Black**.
- The **Brown** wire must be connected to the terminal marked **L** or coloured **Red**.

**Plug must be BS1363/A approved.**

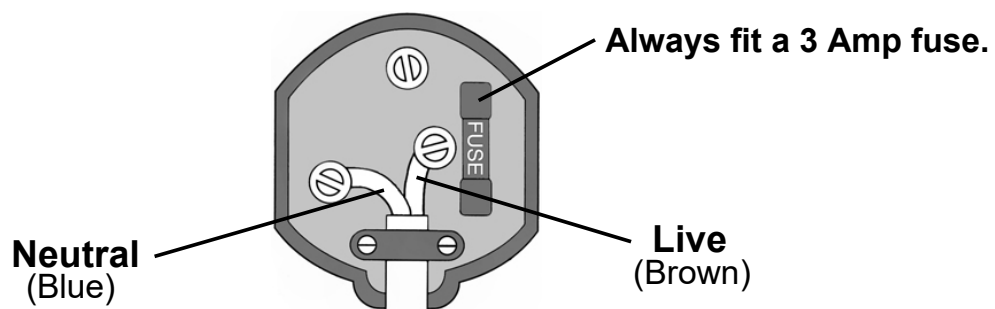

**Ensure that the outer sheath of the cable is firmly held by the clamp**

We strongly recommend that this machine is connected to the mains supply via a Residual Current Device (RCD)

If in any doubt, consult a qualified electrician. **DO NOT** attempt any repairs yourself.



**This symbol indicates that this is a Class II product, and does not require an earth connection.**

# OPERATIONS

## BEFORE EACH USE

What	How
Check the power cable and plug for damage	Conduct a visual inspection and have the cable replaced by an electrician if necessary.
Check the grinding stone	Visual check, Change the grinding stone if necessary (see page 10).
Cleaning the device	Wipe the unit with a damp cloth. Remove grinding residue with a dry brush.

## CORRECTLY SHARPENED BITS

Your bit is correctly sharpened when it has the following characteristics.

- A sharp point in the center of the bit.
- Two sharp and equal cutting edges
- Two trailing edges that are slightly lower than the cutting edges.

## ADJUSTING THE GRINDING STONE

1. Turn the grinding stone height adjustment knob clockwise to raise the stone.
  - This will give you a more aggressive cutting action. This is also useful when you are working with short bits.
2. Lower the stone by turning the adjusting knob anti-clockwise.
  - This will produce a finer ground edge, though it will take longer and require more repetitions.

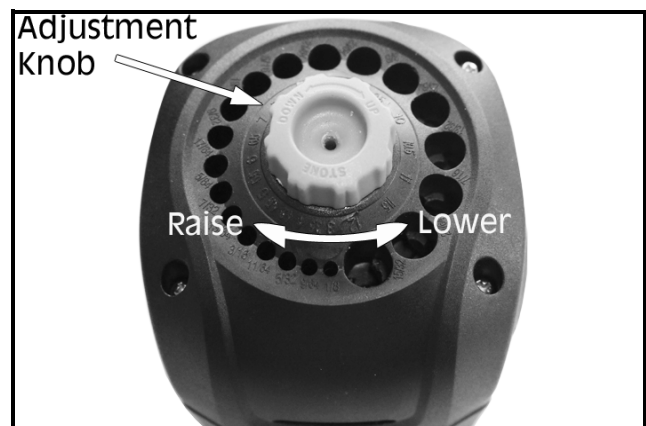

## SHARPENING PROCEDURE

**NOTE:** This sharpener uses a dry grinding stone. **DO NOT** use any sharpening oils or lubricants with this tool.



**WARNING: THIS SHARPENER SHOULD ONLY BE USED TO SHARPEN HSS DRILL BITS. CARBIDE, COBALT AND TITANIUM DRILL BITS SHOULD NOT BE SHARPENED USING THIS TOOL.**

1. Place sharpener on a flat, sturdy surface and plug in.
2. Put a single drill bit (HSS only) into the appropriate hole (3mm - 12mm).
3. Using the height adjustment knob, raise (clockwise) or lower (anti-clockwise) the grinding stone until it touches the drill bit (see 'Adjusting the Grinding Stone' on page 8).

**NOTE:** Do not raise the grinding stone too far as this may damage the housing.

4. Turn the unit on.
  - Exert a slight downward pressure onto the bit and rotate the bit back and forth about 20 degrees while sharpening. Each hole is fluted to help with the rotation.



- The bit must be kept in motion whilst in the machine to avoid uneven sharpening.
5. Turn unit off after approximately 5-10 seconds of sharpening.
    - Examine the drill bit according to the "Sharpening Hints" section below.
  6. Ensure both sides of the drill bit are sharpened using the same amount of time and pressure, pull the drill bit out, rotate it 180° (horizontally) and insert it again.
  7. Repeat the above steps as necessary.
  8. **DO NOT** run the machine for longer than 3 minutes at a time.

**NOTE:** Pre-treat heavily damaged bits by coarsely grinding on a sharpening stone first.

## SHARPENING HINTS

- If the tip of bit starts to turn blue, it is overheating. Reduce the amount of pressure and sharpening time. Cool the bit in water between sharpening cycles.
- If one edge is longer than the other, sharpen the drill bit a little more.

- If you are sharpening a broken (rather than blunt) bit and the time required to restore the shape is too long, rough the bit into shape first using a bench grinder.

## MAINTENANCE & TROUBLESHOOTING

### CHANGING THE GRINDING STONE

1. Make sure that the sharpener is switched off and disconnected from the mains power supply.
2. Remove the four screws that hold the head assembly in place and remove the head assembly.

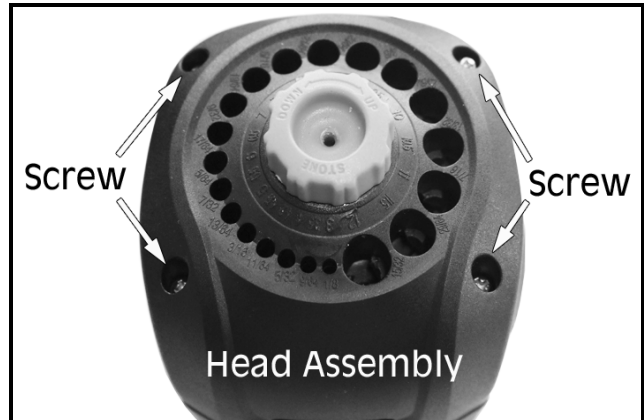

3. Remove the grinding stone assembly.
  - Make sure the spring underneath stays in place around the flat sided spindle.

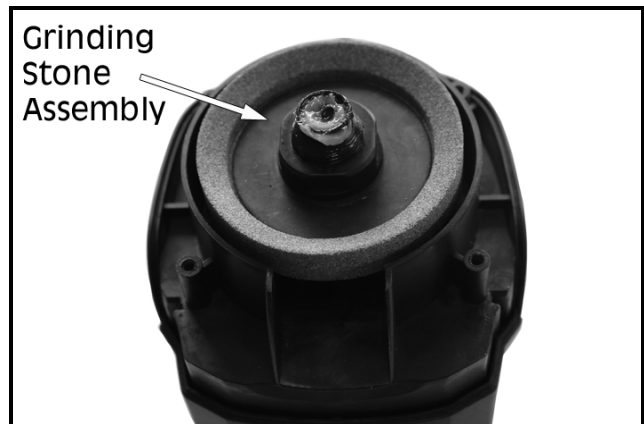

4. Unscrew the nut from the wheel base by turning anti-clockwise.
5. Pop out the wheel base and washer and remove the worn grinding stone.
6. Place new grinding stone onto the wheel base, replace the washer, and screw the nut back in place.

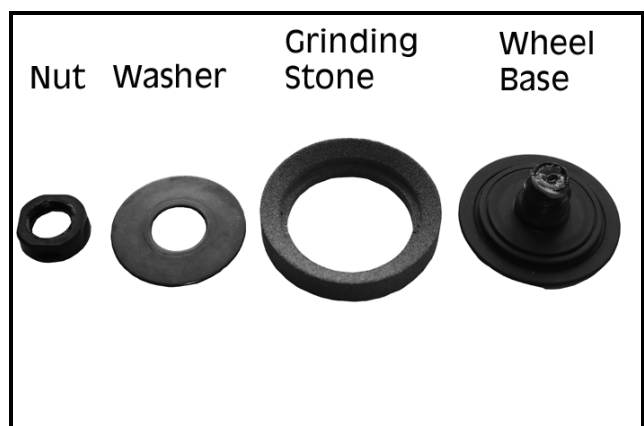

7. Replace wheel assembly onto the unit.

- Make sure that the flat sided spindle lines up with the groove in the wheel base.

8. Replace the head assembly and screws.

**NOTE:** Replacement grinding stones can be purchased via the CLARKE International Parts & Service department (see bottom of page).

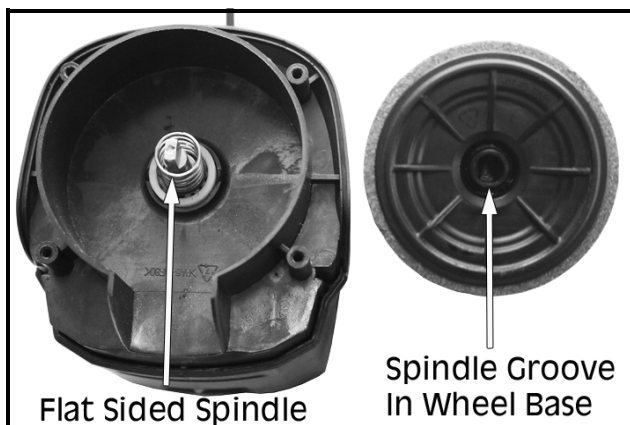

## CLEANING

1. Keep the surface of your sharpener free of grit, dirt, and grease. Use a damp soapy cloth or non-toxic solvents and regular wipe down the grinding stone assembly.
2. **DO NOT** use petroleum based solvents.
3. Keep the air vents free of foreign matter at all times by using an air duster.
4. If the motor does not operate, it may need to be serviced or replaced by a qualified technician.

## TROUBLESHOOTING

Error/Fault	Cause	Remedy
Tool does not work	No power supply	Check the cable, plug and the fuse and replace where necessary.
Insufficient Sharpening Performance	Grinding stone too worn	Replace the grinding stone (see page 10)

If the motor turns on, but the grinding wheel does not spin, make sure the adjustment cylinder's inner flat sided spindle lines up with the outer flats of the spindle as described in Changing the Grinding Stone on page 10/11.

# PARTS LIST AND DIAGRAM

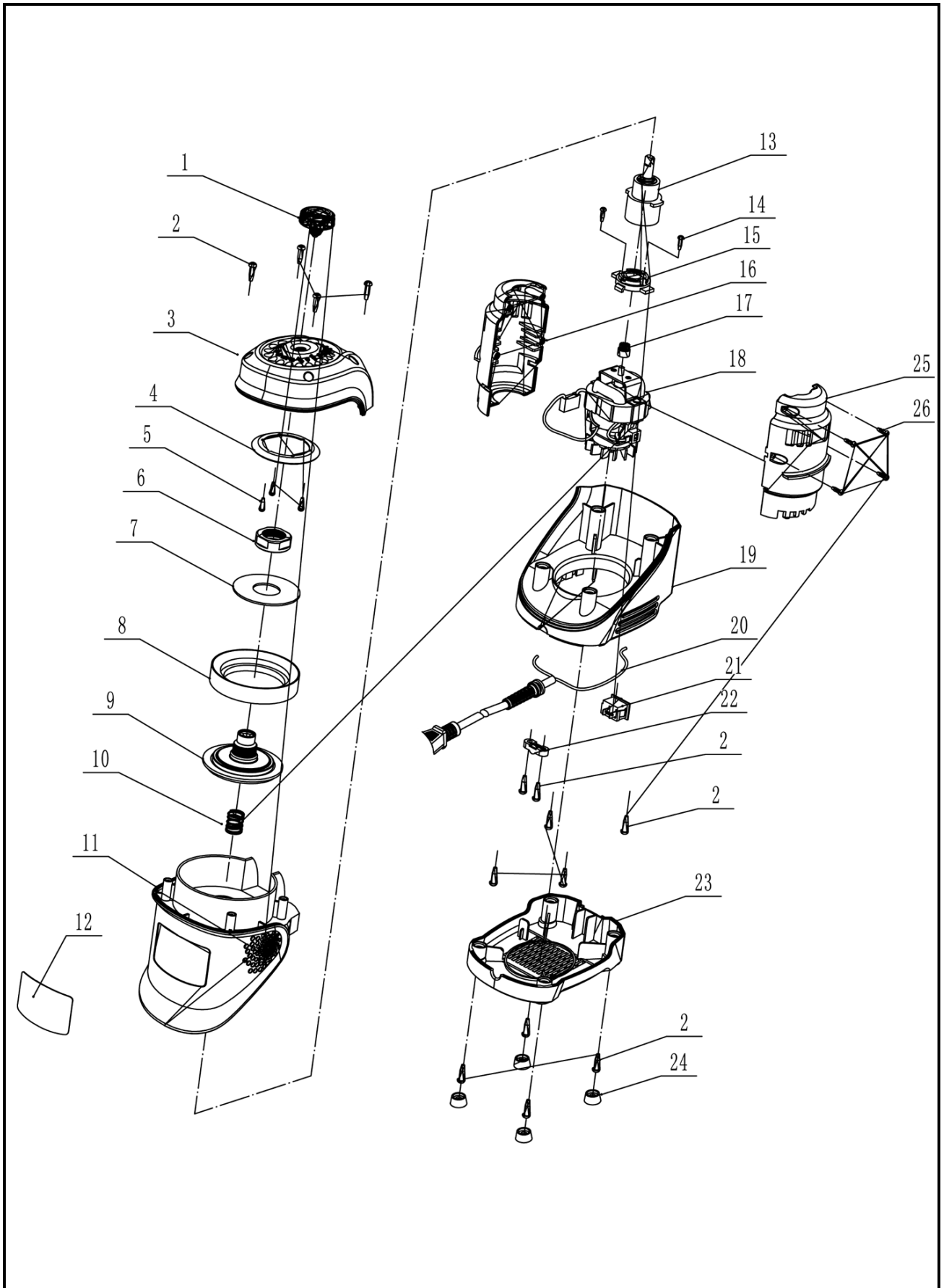

No.	Description	No.	Description
1	Adjustment Knob	14	Screw, M3 x 5
2	Screw, ST4.2 x 14	15	Junction Plate
3	Head Assembly	16	Right Side Motor Casing
4	Cap Ring	17	Gear
5	Screw, ST2.9 x 8	18	Motor
6	Adjustment Cylinder	19	Lower Motor Housing
7	Washer	20	Power Cable
8	Grinding Stone	21	On/Off Switch
9	Wheel Base	22	Tension Disc
10	Spring	23	Base
11	Upper Motor Housing	24	Rubber Pad
12	Lable	25	Left Side Motor Casing
13	Reducer Casing	26	Screw, ST2.9 x 10

---

## SPECIFICATION

---

Model Number	<b>CBS20</b>
Voltage	230 V @ 50Hz
Wattage	95 W
Drill Bit Sizes And Type	3 mm to 12 mm. HSS only
Grinding Stone Diameter	75 mm
IP Rating	IP20
Duty Cycle	S1, Constant
No Load Speed	1500 rpm
Dimensions (H x W x D)	180 mm x 120 mm x 130 mm
Weight	1.12 Kg

# DECLARATION OF CONFORMITY - UKCA



Hernnall Street, Epping, Essex CM16 4LG

## DECLARATION OF CONFORMITY

This is an important document and should be retained.

**We hereby declare that this product(s) complies with the following statutory requirement(s):**

*Electromagnetic Compatibility Regulations 2016*

*Supply of Machinery (Safety) Regulations 2008*

*The Restriction of the Use of Certain Hazardous Substances in Electrical and Electronic Equipment Regulations 2012*

**The following standards have been applied to the product(s):**

*EN 55014-1:2017, EN 55014-2:2015, EN 61000-3-2:2014, EN 61000-3-3:2013,*

*EN 62841-1:2015+AC15, EN 62841-3-4:2016+A11:17, EN ISO 12100:2010, IEC 62321-1:2013,*

*IEC 62321-2:2021, IEC 62321-3-1:2013, IEC 62321-4:2013+A1:2017, IEC 62321-5:2013,*

*IEC 62321-6:2015, IEC 62321-7-1:2015, IEC 62321-7-2:2017, IEC 62321-8:2017,*

*EN ISO 17075-1:2017*

The technical documentation required to demonstrate that the product(s) meet(s) the requirement(s) of the aforementioned legislation has been compiled and is available for inspection by the relevant enforcement authorities.

**The UKCA mark was first applied in: 2022**

**Product Description:** Electric Drill Bit Sharpener  
**Model number(s):** CBS20  
**Serial / batch Number:** N/A  
**Date of Issue:** 28/07/2022

**Signed:**

**J.A. Clarke**  
**Director**

# DECLARATION OF CONFORMITY - CE



**Clarke**<sup>®</sup>  
**INTERNATIONAL**

Fitzwilliam Hall, Fitzwilliam Place, Dublin 2

## DECLARATION OF CONFORMITY

**This is an important document and should be retained.**

**We hereby declare that this product(s) complies with the following directive(s):**

- 2014/30/EU Electromagnetic Compatibility Directive*
- 2006/42/EC Machinery Directive*
- 2011/65/EU Restriction of the Use of Certain Hazardous Substances in Electrical and Electronic Equipment Directive*

**The following standards have been applied to the product(s):**

- EN 55014-1:2017, EN 55014-2:2015, EN 61000-3-2:2014, EN 61000-3-3:2013,*
- EN 62841-1:2015+AC15, EN 62841-3-4:2016+A11:17, EN ISO 12100:2010, IEC 62321-1:2013,*
- IEC 62321-2:2021, IEC 62321-3-1:2013, IEC 62321-4:2013+A1:2017, IEC 62321-5:2013,*
- IEC 62321-6:2015, IEC 62321-7-1:2015, IEC 62321-7-2:2017, IEC 62321-8:2017,*
- EN ISO 17075-1:2017*

The technical documentation required to demonstrate that the product(s) meet(s) the requirement(s) of the aforementioned directive(s) has been compiled and is available for inspection by the relevant enforcement authorities.

**The CE mark was first applied in: 2022**

**Product Description:** Electric Drill Bit Sharpener  
**Model number(s):** CBS20  
**Serial / batch Number:** N/A  
**Date of Issue:** 28/07/2022

**Signed:**

**J.A. Clarke**  
**Director**

# A SELECTION FROM THE VAST RANGE OF

# Clarke®

## QUALITY PRODUCTS



**AIR COMPRESSORS**  
From DIY to industrial, Plus air tools, spray guns and accessories.

**GENERATORS**  
Prime duty or emergency standby for business, home and leisure.

**POWER WASHERS**  
Hot and cold, electric and engine driven - we have what you need

**WELDERS**  
Mig, Arc, Tig and Spot. From DIY to auto/industrial.

**METALWORKING**  
Drills, grinders and saws for DIY and professional use.

**WOODWORKING**  
Saws, sanders, lathes, mortisers and dust extraction.

**HYDRAULICS**  
Cranes, body repair kits, transmission jacks for all types of workshop use.

**WATER PUMPS**  
Submersible, electric and engine driven for DIY, agriculture and industry.

**POWERTOOLS**  
Angle grinders, cordless drill sets, saws and sanders.

**STARTERS/CHARGERS**  
All sizes for car and commercial use.



## PARTS & SERVICE: 0208 988 7400

**Parts Enquiries**  
[Parts@clarkeinternational.com](mailto:Parts@clarkeinternational.com)

**Servicing & Technical Enquiries**  
[Service@clarkeinternational.com](mailto:Service@clarkeinternational.com)

SALES: UK 01992 565333 or Export 00 44 (0)1992 565335

**Clarke® INTERNATIONAL** Hemnall Street, Epping, Essex CM16 4LG  
[www.clarkeinternational.com](http://www.clarkeinternational.com)